

SHACK MOUNTED DRILL RIG

VD8000

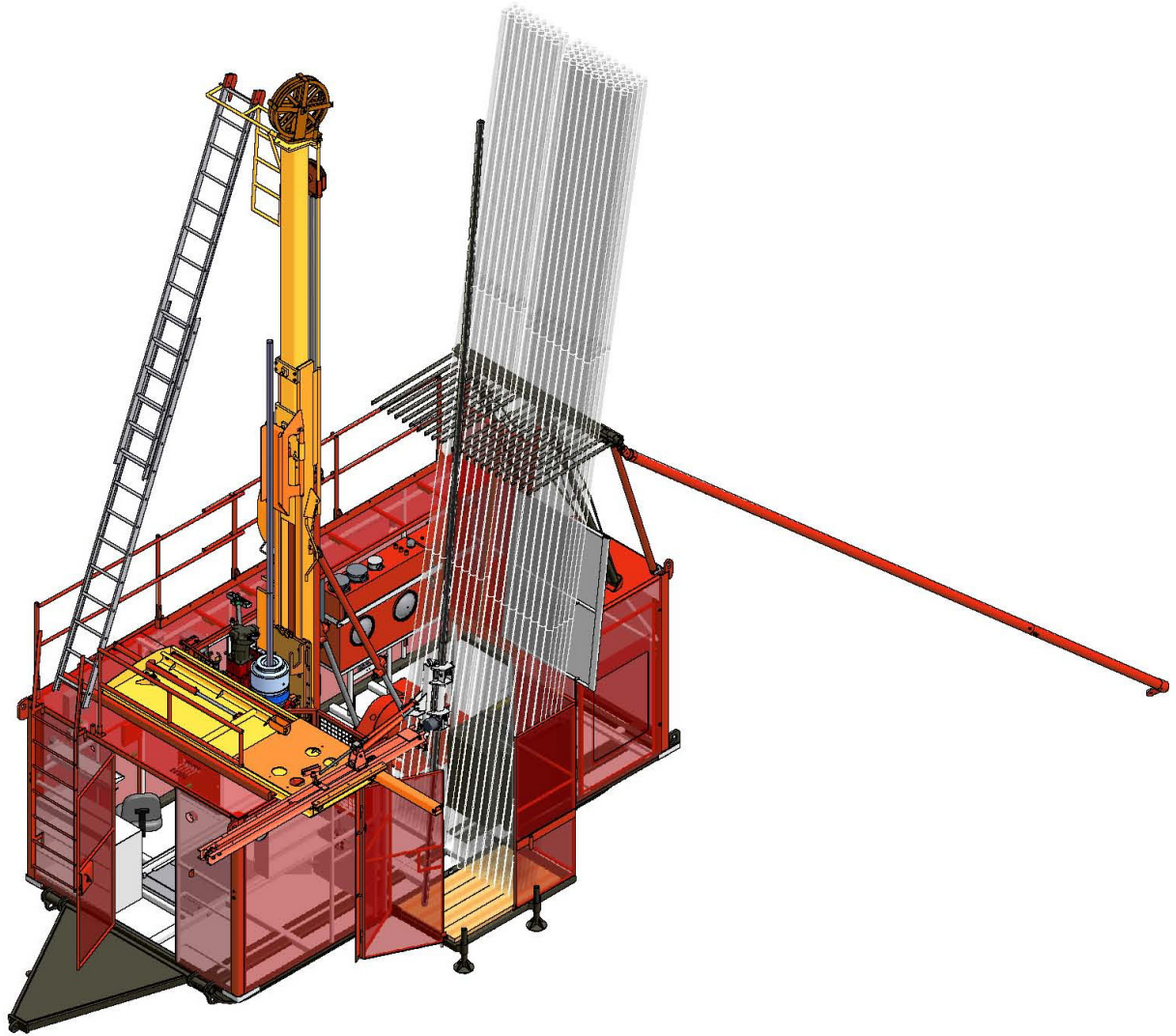

**Atelier
Val d'Or inc.**

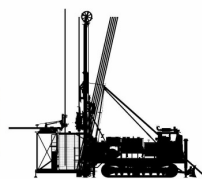

1096 Rue de l'Écho
Parc Industriel
Val-d'Or (Québec) J9P 6X8

☎ 819-824-3676

☎ 819-824-2891

✉ ateliervd@ateliervd.qc.ca

TECHNICAL SPECIFICATIONS

Model	VD8000
Type	Skid mounted, enclosed shack, all hydraulic chuck drive core drill, specially designed for diamond core drilling up to the rated specifications.
Drill mast	Capacity to drill between 90° and 45°.
Diesel engine	The most frequently used power units are John Deere 200HP JD6068TF250 or John Deere 250HP JD6081AF001 with a normal operating speed up to 2,200 RPM (operating RPM can vary depending on pump configuration and option chosen).
Fuel tank capacity	160 litres (42 US gal.)
Pump drive	FUNK triple pump drive (series 28000) with ratio 1.27:1
Rotation head	AVD (Atelier Val D'Or inc.) type with chain drive head for hydraulic chuck (customer choice) ratio 12/24 on "H" size head, and 12/29 on "P" size head.
Transmission	FUNK 4 speeds transmission (Ratio 1 st 6.63:1, 2 nd 3.17:1, 3 rd 1.72:1, 4 th 1:1)
Head table	Hydraulic cylinder directly coupled to the rotation head table. The travel is 3m (10ft) or 3.3m (11ft). The pull down and pull up capacities are 13,526 kg (29,820 lbs) and 25,650 kg (56,548 lbs) both at a pressure of 4,500PSI.
Pull cylinder	Hydraulic cylinder with 16,833 kg (37,110 lbs) of maximum pull at 4,500PSI.
Water pump	Standard BEAN 435 or PRATISSOLI KF40 (customer choice possible)
Rod clamp	BOYLES style for "B" to "P" sizes.
Wireline winch	The capacity of the wireline winch is 3,500m (11,480ft) for 3/16in wireline rope, depending on the option chosen.
Hydraulic	Full flow 25 micron Beta rated return oil filtration. Water/oil, air/oil hydraulically motorized (optional) and air/oil (optional, installed on the diesel engine) hydraulic coolers.
Hydraulic tank capacity	323 litres (85 US gal.)
Maximum pull capacity	42,483 kg (93 658 lbs) @ 4,500 PSI with feed and pull cylinder.
Overall weight of drill	approx. 13,640 kg (30 000 lbs)
Rod handler	Standard

Rod rack maximum stacking capacity:

Rod size		BQ (Ø2.19")*	NQ (Ø2.75")	HQ (Ø3.50")	PQ (Ø4.50")
Qty (9-metre sections)		368	289	195	120
Depth in:	metres	3,312	2,601	1,755	1,080
	feet	10,866	8,533	5,757	3,543

* : comb configured for NQ rods

**Atelier
Val d'Or inc.**

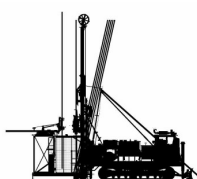

1096 Rue de l'Écho
Parc Industriel
Val-d'Or (Québec) J9P 6X8

☎ 819-824-3676
☎ 819-824-2891
✉ ateliervd@ateliervd.qc.ca

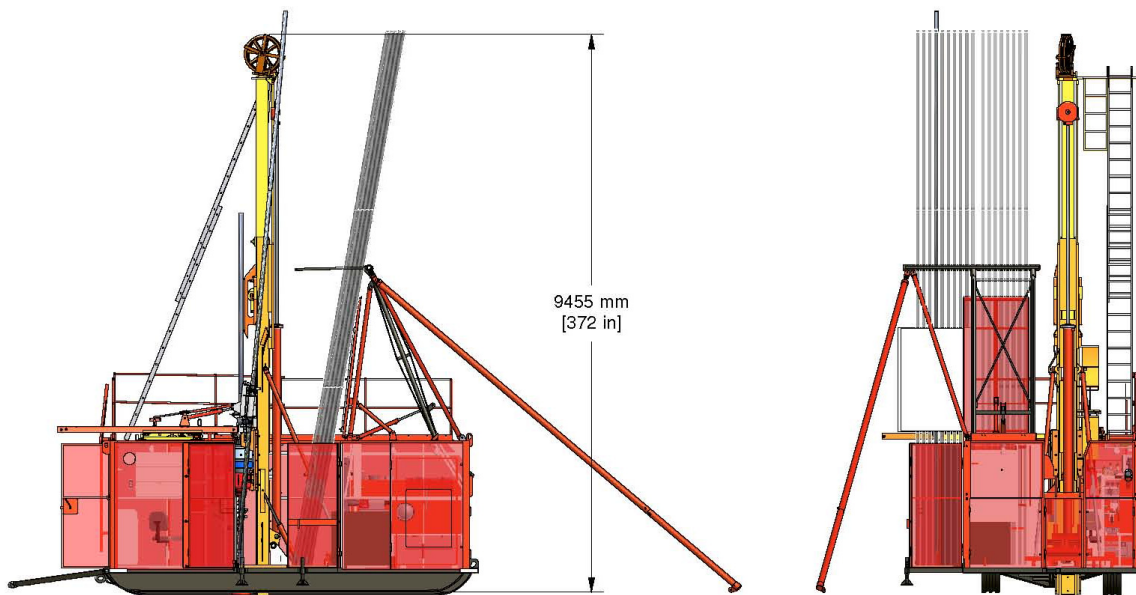
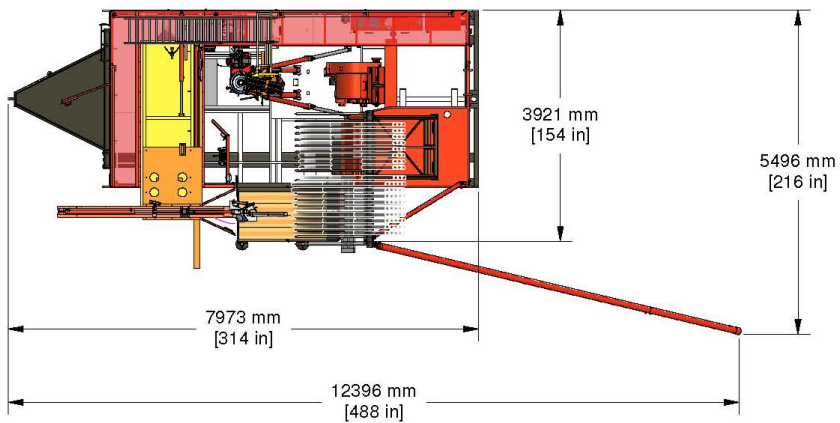

DRILL IN WORKING POSITION (mast shown at 90°)

**Atelier
Val d'Or inc.**

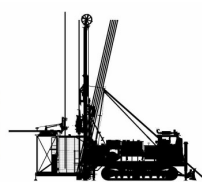

1096 Rue de l'Écho
Parc Industriel
Val-d'Or (Québec) J9P 6X8

☎ 819-824-3676

☎ 819-824-2891

✉ ateliervd@ateliervd.qc.ca

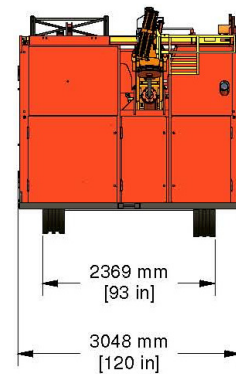
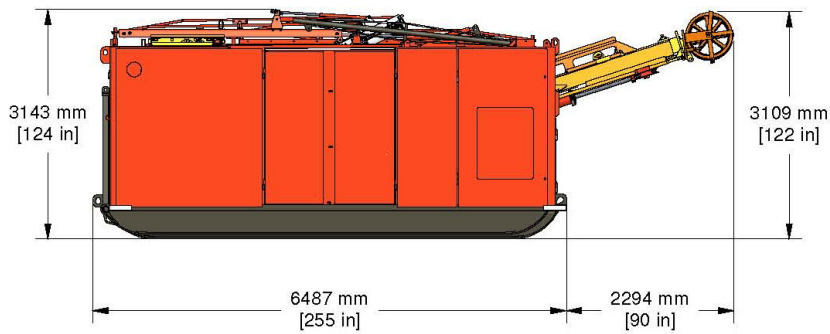
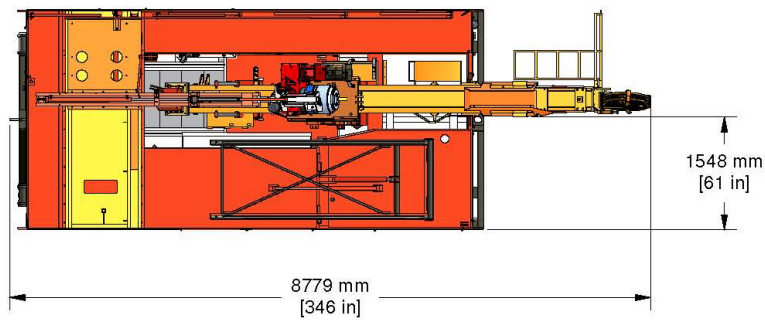
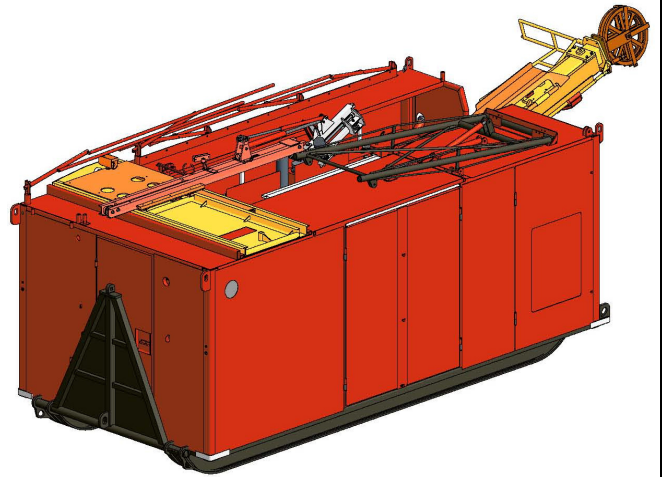

DRILL IN TRANSPORT POSITION

**Atelier
Val d'Or inc.**

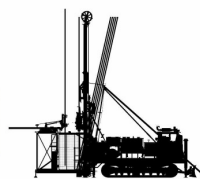

1096 Rue de l'Écho
Parc Industriel
Val-d'Or (Québec) J9P 6X8

☎ 819-824-3676
☎ 819-824-2891
✉ ateliervd@ateliervd.qc.ca